

Maßblatt für
Treppenlift DELTA

ohne Kontaktboden!

STEIFUNGSWINKEL:
min. 15°
max. 45°

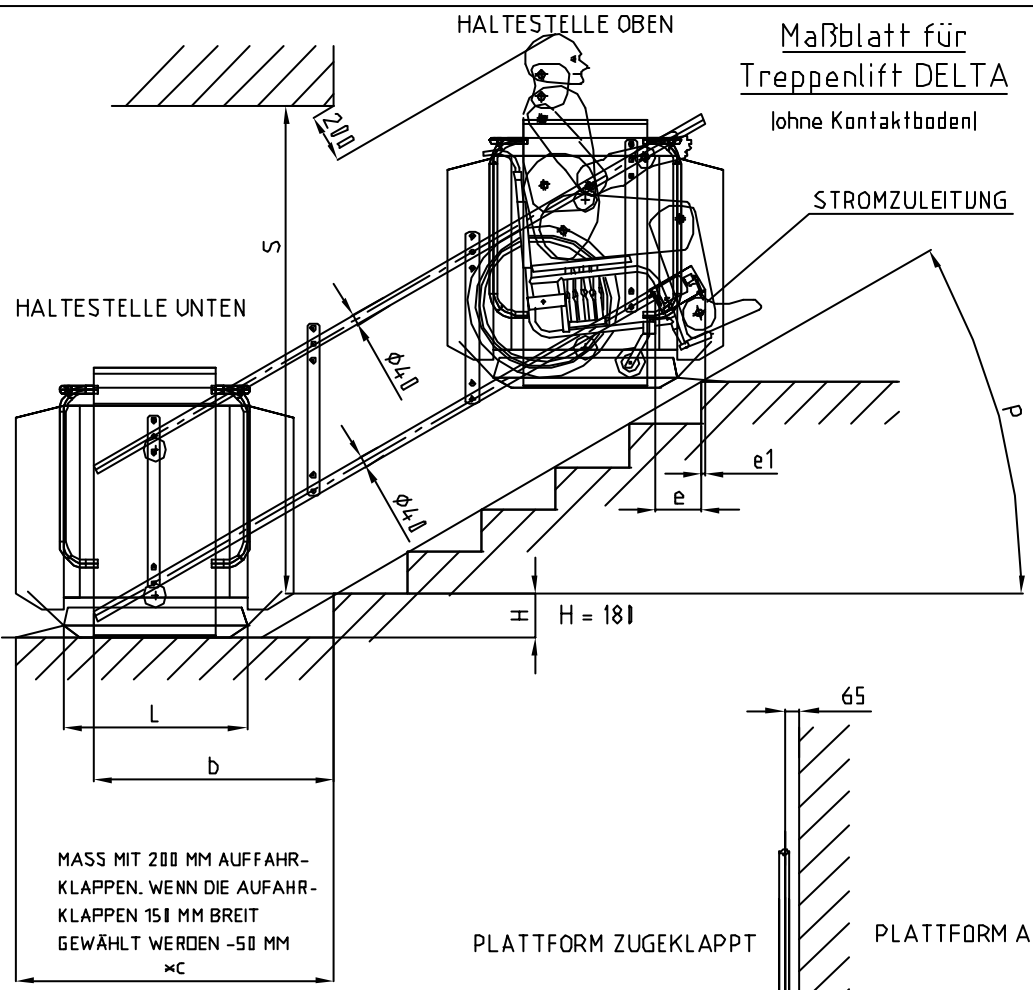

PLATTFORM ZUGEKLAPPT

PLATTFORM AUFGEKLAPPT

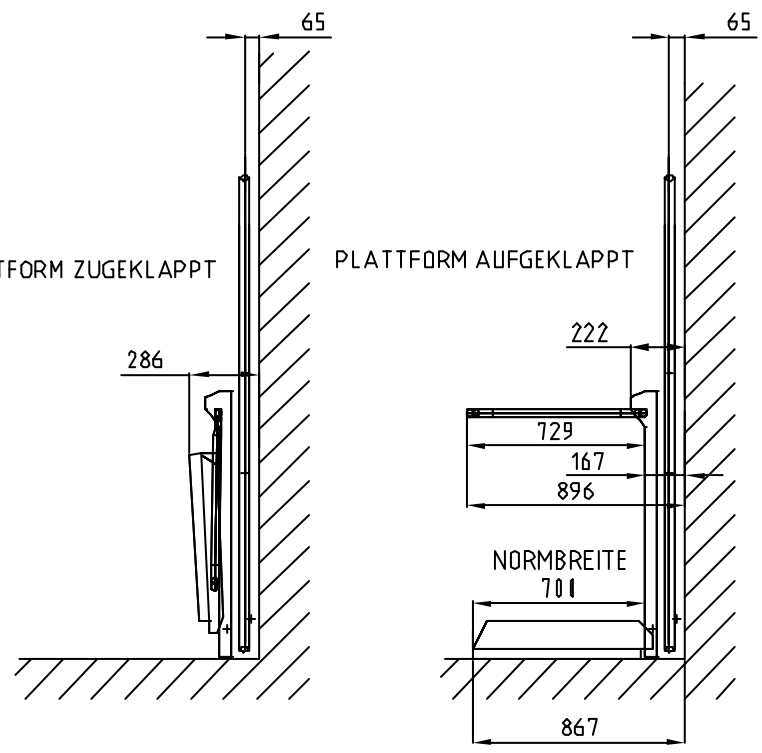

15°	1,5 L + 961	L + 897
20°	1,5 L + 787	L + 724
25°	1,5 L + 691	L + 630
30°	1,5 L + 621	L + 565
35°	1,5 L + 567	L + 518
40°	1,5 L + 521	L + 481
45°	0,5 L + 481	L + 451
P	b	*c
STEIFUNG	L - SONDERGRÖSSEN	

15°	1336	1647	169	38	1790	1411	1797	244	-37	1817	1461	1897	294	-87	1826
20°	1162	1474	160	48	1848	1237	1624	235	-27	1884	1287	1724	285	-77	1896
25°	1065	1380	174	33	1917	1141	1530	249	-42	1964	1190	1631	299	-92	1979
30°	996	1315	190	14	1994	1171	1465	265	-61	2052	1121	1565	315	-111	2071
35°	942	1268	208	-8	2081	1117	1418	283	-83	2151	1067	1518	333	-133	2174
40°	896	1231	229	-34	2181	971	1381	304	-109	2265	1021	1481	354	-159	2293
45°	856	1201	251	-63	2300	931	1351	326	-138	2401	981	1451	376	-188	2433
P	b	*c	e	e1	S	b	*c	e	e1	S	b	*c	e	e1	S
STEIFUNG	L = 750				L = 900				L = 1000						

Anderungen vorbehalten!